

Manko T. A.¹, Husarova I. A.², Potapov A. M.², Simbirkina A. N.², Falchenko Yu. V.³, Salenko A. F.⁴, Solntsev V. P.³

¹ Oles Honchar Dnipro National University. Ukraine, Dnipro

² Yuzhnoye, State-owned Design Office named after M. K. Yangel. Ukraine, Dnipro

³ E. O. Paton Electric Welding Institute of NAS of Ukraine. Ukraine, Kyiv

⁴ Kremenchuk Mykhailo Ostrohradskyi National University. Ukraine, Kremenchuk

⁵ Frantsevich Institute for Problems of Materials Science of NAS of Ukraine. Ukraine, Kyiv

PRODUCTION OF SPACEPLANE THERMAL PROTECTION SYSTEMS: SCIENTIFIC AND TECHNOLOGICAL MATTERS

A technology has been created to produce permanent joints of $(\text{Ni}_{20}\text{Cr}_{5.95}\text{Al})\text{-Y}_2\text{O}_3$ structures elements by diffusion welding in vacuum through interlayers and vacuum brazing with a Ni-B-W powder-brazing alloy developed by the authors. [dx.doi.org/10.29010/085.1]

Keywords: thermal protection system; high-temperature alloy; diffusion welding; welded joints; electron beam evaporation; brazing.

Spaceplanes like Space Shuttle and Buran will open a new page in space exploration and make it more affordable thanks to the reuse of expensive space technology.

The first thermal protection system capable of withstanding aerodynamic pressure loads and ensuring thermal protection of a spacecraft was developed by American specialists to be exploited in VentureStar reusable spacecraft. The thermal protection system consists of diamond-shaped, three-layer honeycomb metal panels with fibrous insulation attached to the panel's inner surface. [1] Three-layer outer panels made of Inconel 617, with a honeycomb core, were designed and manufactured by the Goodrich Company (United States) to protect the outer surface of the X-33 reusable spacecraft [2] and by NASA Langley

Research Center to protect cryogenic tanks of the reusable space transportation system [3] and to ensure vehicle's thermal protection and enhanced resistance to high-velocity collisions with space debris in orbit (see Figure 1). [4]

One of the main difficulties in the development of reusable spaceplanes is to ensure thermal protection for the safe descent through the Earth's atmosphere during reentry. Permanent joints between Space Shuttle's and Buran's stressed skin and ceramic thermal protection tiles have not proved themselves necessary in spaceplanes since they have been found unable to ensure required reliability. Today a special interest is paid to thermal protection systems consisting of detachable tiles. The underside of reusable spaceplanes which experiences up to 1100 °C is given particular attention. A tile

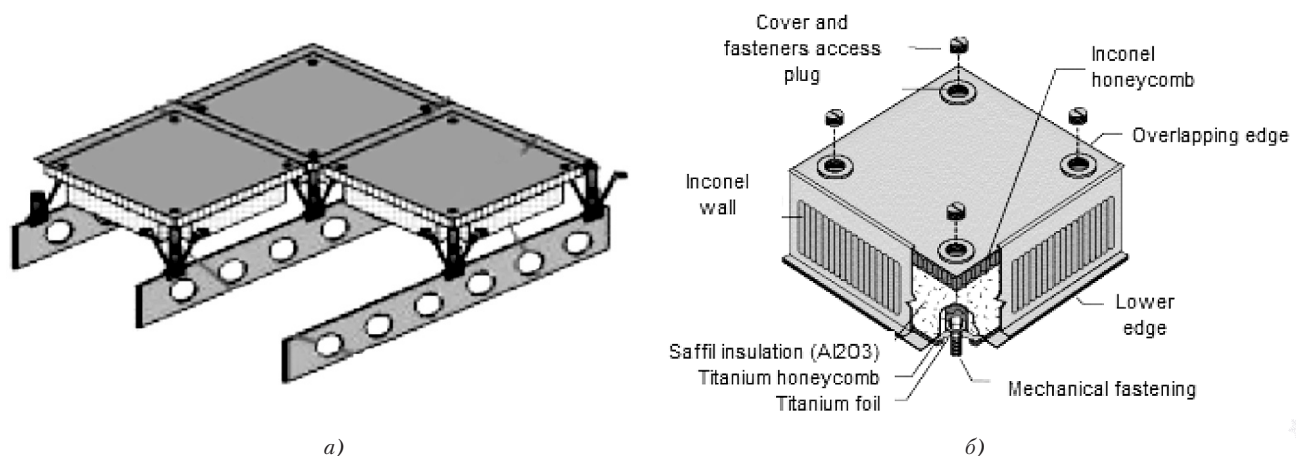

Fig. 1. Thermal protection systems with three-layer metal panels
a – of VentureStar; b – for enhanced collision resistance

thermal protection system comprises inner insulation and a heat-resistant metal outer surface.

Specialists from the European company Astrium have developed a similar multilayer thermal protection system with inner insulation and a three-layer metal outer panel with a honeycomb core for the X-38 spaceplane.

So the promising approaches to the development of a reliable detachable thermal protection system for the orbital spaceplane underside are the exploitation of heat-resistant three-layer outer panels with a honeycomb core and the use of high-temperature nichrome-based superalloys being able to withstand up to 1100 °C such as PM-1000 (Europe) and Inconel 617 (United States) as production materials for the panels.

The first promising tile thermal protection system developed in Ukraine comprises a honeycomb core and a three-layer outer panel made of (Ni20Cr5.9Al)-Y₂O₃, a nichrome-based powder alloy strengthened with yttrium dioxide. Preliminarily sintered powder workpieces were rolled to get 0.4 mm and 0.15 mm thick surfaces of the panel. For lower specific weight, the alloy contains 5.95% of aluminum which decreases the density to 7500 kg/m³ and increases high-temperature strength to 57 MPa at 1200 °C and thermal resistance to 6,82216E-06 g/cm². However, the high content of aluminum results in lower plasticity of the alloy – its specific elongation does not exceed 11% within 20–1200 °C, which makes it necessary to try out the techniques of spaceplane thermal protection system development.

The difficulty of making a (Ni20Cr5.95Al)-Y₂O₃ thermal protection system comprising three-layer panels with a honeycomb core is, among others, in getting fixed permanent joints. The difficulty is caused by the presence of persistent oxide on the surface of high-temperature nichrome-based alloys as well as by poor plasticity of this group of materials. The disperse intermetallic compounds form a surplus γ'-phase which blocks the glide planes and, in particular conditions, impedes simple shear processes. This is why the (Ni20Cr5.95Al)-Y₂O₃ alloy is a hard-to-weld material, notwithstanding all its advantages. [5]

The authors have conducted some studies which proved diffusion welding and brazing in vacuum to be the most appropriate techniques to join separate components into an assembled structure.

Temperature, specific pressure and duration of the process are the key parameters of diffusion welding in vacuum.

Heating of parts increases thermal mobility of atoms and ensures a required rate of diffusion processes, makes for degassing of metals, solution and dissociation of oxide and adsorbed films. Besides, the process of welding of nickel-chromium-aluminum-based alloys requires high temperatures that is explained by activation of surfaces due to dissolution of the strengthening phase γ'. [6] Interlayers of various structures are used in NiCr-based alloys as an additional factor of surface activation. High-temperature nichrome alloys can be attached to each other by diffusion welding in vacuum at 1140–1240 °C and under 15–60 MPa. [6, 7]

Diffusion welding at 1200 °C under specific pressure of 40 MPa was conducted to try out the techniques of permanent joining of the (Ni20Cr5.95Al)-Y₂O₃ alloy. Specific pressure in the point of contact shall be sufficient to induce plastic deformation of microroughnesses and cause no considerable deformation of welded workpieces. Specific pressure required for the (Ni20Cr5.95Al)-Y₂O₃ alloy is 40 MPa because the alloy's yield point is 51 MPa at 1200 °C. The duration of the process is 20 minutes.

Multilayer Ni-Al and Cu-Ti foils produced by electron beam evaporation and deposition in vacuum as well as porous Co, Cu, Ni foils with a thickness of 25 to 40 micron were analyzed on the possibility of using them as interlayers. It should be noted that the mentioned techniques of welding through interlayers are good only for samples with high stiffness.

For welding of thin-layer (Ni20Cr5.95Al)-Y₂O₃ samples through multilayer, Ni-Al and Cu-Ti interlayers, the average values of microhardness in the area of attachment were 4.34 to 4.64 GPa that indicates the formation of intermetallics. The use of Co-based inter-

layers has resulted in higher porosity of welded joints. The use of Cu and Ni-based interlayers during the welding process has resulted in considerably lower porosity and no oxide film formation. Microhardness of the material in the area of attachment was 2.2–2.3 GPa which is equal to the original hardness of the alloy (see Figure 2).

It has been found from the conducted studies that the most appropriate interlayer for diffusion welding in vacuum is one made of porous nickel, with the melting temperature of 1455 °C which is higher than the

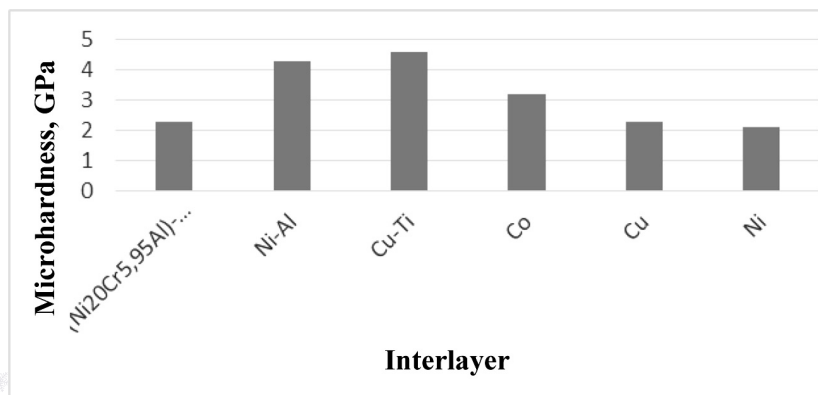

Fig. 2. Microhardness of welded joints of the (Ni20Cr5.95Al)-Y₂O₃ alloy with interlayers of different chemical composition

melting temperature of copper (1083 °C). When a plastic interlayer of porous nickel foil (with the yield point lower than that of the (Ni20Cr5,95Al)-Y₂O₃ alloy) is used for diffusion welding in vacuum, the pores get healed and the conditions of diffusion interaction arise in the contact, due to which the welded surfaces are joined. [8]

The selected welding technique implies heating of samples to 1200 °C, application of 40 MPa of specific pressure, holding under the load for 20 minutes, unloading, and chilling down to 40–50 °C. However, when samples of a three-layer panel with a honeycomb core were welded by this technique, the integrity of the core was destroyed (see Figure 3a). The fall of temperature from 1200 °C to 1100 °C and to 1000 °C does not ensure the integrity of the core either. Then, diffusion welding in vacuum was done at lower temperatures (900 and 800 °C) and pressure to eliminate the material's deformation (Figure 3b).

The conducted microstructure studies of the obtained welded joints prove that the temperature of 900 °C gives a structure with negligible defects (Figure 4a) while a temperature decreased to 800 °C gives worse quality of the welded seam (Figure 4b).

The three-layer panels were welded by using specially developed attachments [9] which allowed lower

welding pressure and the unlimited deformation of the honeycomb core.

A coated porous nickel interlayer was used for higher technological effectiveness. Nickel was applied on the panels and the honeycomb core's surfaces to be welded by the method of electron beam evaporation and deposition in vacuum after ion etching of the surfaces.

It has been found thereby that flawless joints of three-layer (Ni20Cr5.95Al)-Y₂O₃ structures with a honeycomb core can be produced by diffusion welding in vacuum through porous nickel layers at the temperature of 900 °C and under the pressure of 4 MPa for 20 minutes.

The strength of the joints produced by diffusion welding of the (Ni20Cr5.95Al)-Y₂O₃ alloy in vacuum is 264.3 MPa, which is 85% of the strength of a 0.15 mm thick lower surface of the panel.

The quality of welded joints of the honeycomb core with the panels was assessed and inspected by the thermographic method and a FLIR A320 thermal imager. A pulse of heat flux was directed to each of the prototype's tiles. The results were presented in heat patterns, the digital images of thermal fields from the side of the opposite surface. When a welded joint between a honeycomb cell and the surface is broken, there is no

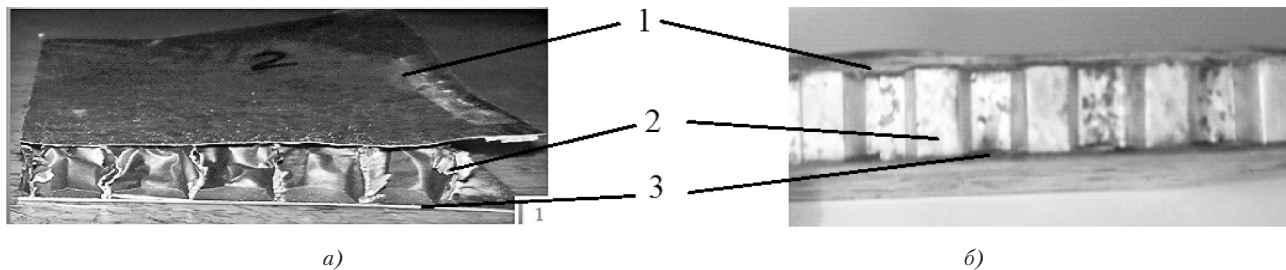

Fig. 3. Three-layer (Ni20Cr5,95Al)-Y₂O₃ panels after welding at 1200 °C (a) and 900 °C (b)

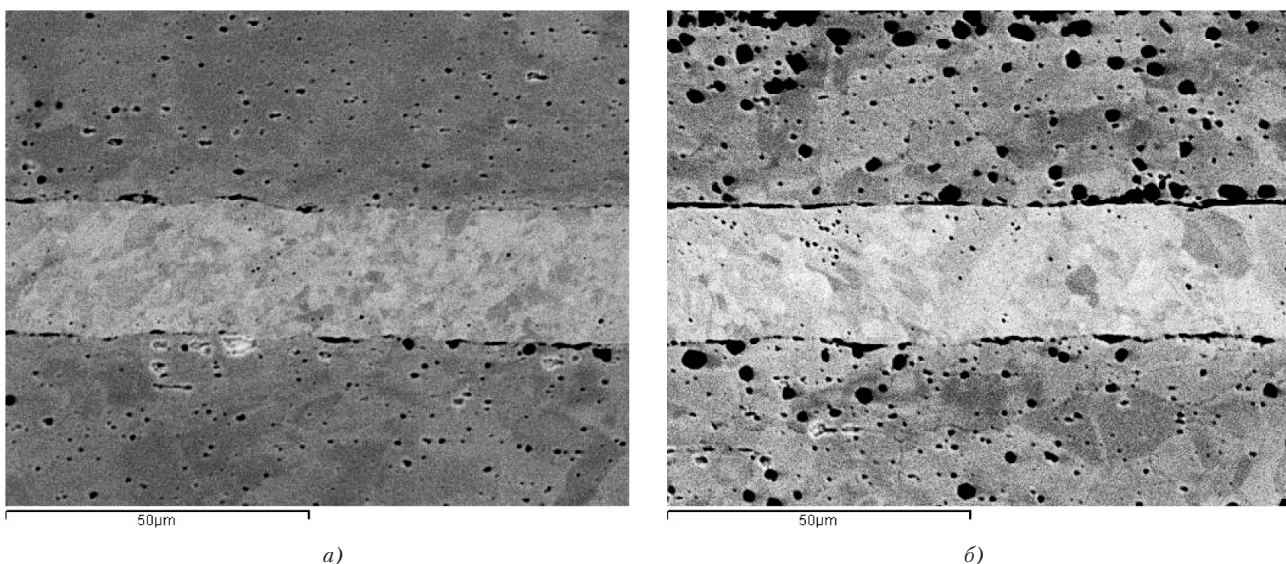

Fig. 4. Microstructure of a welded joint of (Ni20Cr5,95Al)-Y₂O₃ samples with a nickel interlayer
a – welding temperature 900 °C, b – welding temperature 800 °C

thermal contact between them so the joint is not shown on the heat pattern and a defect area appears.

A prototype of an outer panel, 144 x 144 mm, was made to try out the technique (Figure 5a). Figure 5b shows the areas (rounded with white dashes) with no welded joint between two edges on the inner side of the surface of the tested prototype. No defects of the outer surface were found (Figure 5c).

The performance of the three-layer panel's prototype was tested under a combination of transportation, launch and flight loads which imitated the operational ones. For each test, the loads were applied successively in three directions. The integrity of the prototype was checked and the quality of welded joints between honeycomb cells was inspected by the thermographic method after each test. The appearance of the prototype has not changed. Heat patterns of the tested structure are identical for all phases of load application and correspond to the digital image shown in Figures 5b and 5c. No new defects have been found upon completion of all the tests.

The results of the tests on the prototype of a three-layer (Ni20Cr5,95Al)-Y₂O₃ panel demonstrated no damage of integrity of the structure and welded joints between the honeycomb cells and the surfaces under the transportation, launch, and flight loads.

U-fasteners are used to assemble three-layer panels (Figure 6).

Eight fixed, permanent joints were made to attach the edges of the panels and the U-fasteners to assemble

four single panels. In this case, the pieces made of heat-resistant nickel alloys were attached by brazing which makes it possible to join a large number of pieces in several points during one heating cycle. [9] Since brazing requires high temperatures, the process was done in vacuum and with the use of a powder-brazing alloy to prevent the formation of oxide films.

The following theoretical and experimental researches have been conducted in order to select a material of the powder-brazing alloy as well as the techniques to braze joints of the (Ni20Cr5.95Al)-Y₂O₃ alloy in vacuum.

Analytical modeling of temperature fields and heat fluxes during brazing of a flat plate has shown a non-uniform temperature distribution over the plate's surface, which results in deformation of the plate or the entire structure. The introduction of thermal ballasts near the plate gave redistributed thermal loading and heating non-uniformity decreased by 20–30 °C. The deformation can be reduced by using pressure plates, the weight mp of which shall be sufficient to prevent from distortion and, at the same time, cause no considerable deformations of the structure made of the (Ni20Cr5,95Al)-Y₂O₃ alloy.

Taking into account the results of the applied modeling, all experimental researches were done with the use of thermal ballasts and pressure plates.

The available high-melting nickel-based brazing alloys containing the depressants for high-temperature

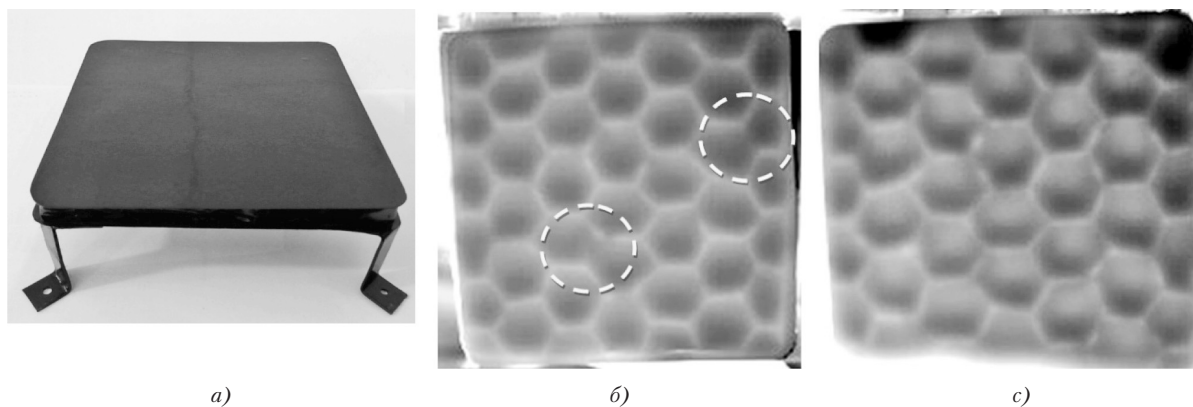

Fig. 5. Panel's prototype and heat patterns of the inner and outer surfaces
a – prototype; b – inner surface; c – outer surface

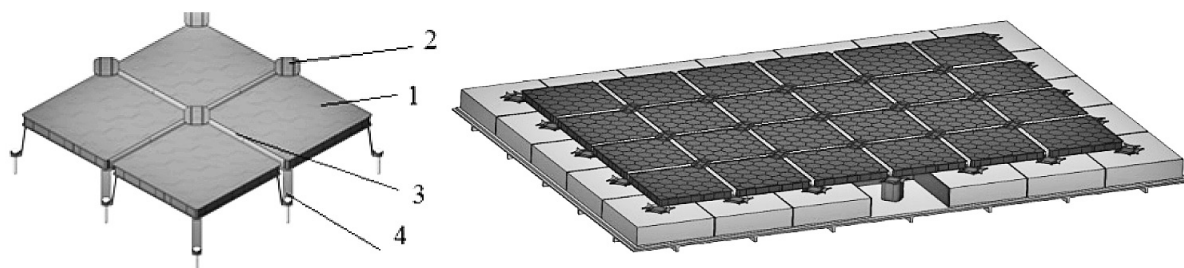

Fig. 6. Components of an assembled thermal protection system:
1 – outer three-layer panel, 2 – mounting attachment, 3 – U-fastener, 4 – support

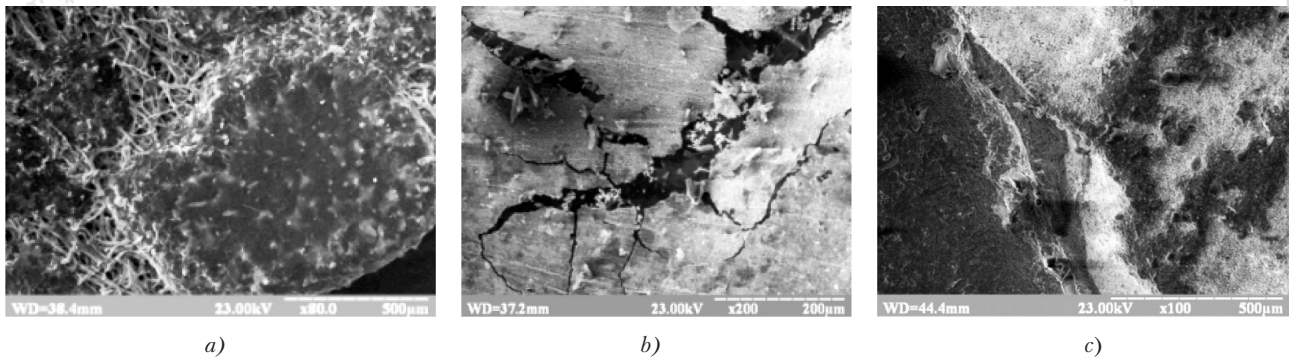

Fig. 7. Microstructure of joints of the (Ni20Cr5,95Al)-Y₂O₃ alloy brazed in vacuum under 10⁻³ Pa at temperatures of 1300 °C (a), above 1350 °C (b), 1350 °C (c)

NiCr alloys does not give maximum operating temperatures for thermal protection systems within 1100–1200 °C. The authors have developed a Ni-B-W powder-brazing alloy. It was proved during experiments that the temperature of (Ni20Cr5,95Al)-Y₂O₃ brazing in vacuum (10⁻³ Pa) with the use of the Ni-B-W powder-brazing alloy shall be near 1330–1350 °C. A lower temperature of about 1300 °C does not give a proper joint because of no adhesion of the powder-brazing alloy to the base surface (see Figure 7a). A temperature above 1355 °C causes the destruction of samples through burnout and distortion (Figure 7b). A good, porousless joint is obtained at 1350 °C (Figure 7c).

To prove the correctness of selecting the vacuum brazing technique, two plates of different thickness (0.4 and 0.15 mm, respectively) were joined with a 7.2 mm overlap. To achieve a tight contact, the surfaces were exposed to 0.1 MPa prior to brazing. The results of the microstructure analysis show that insufficient adhesion of samples gives poor quality of joints (Figure 8). The area where it was no tight contact between the surfaces has higher porosity and contains some unmelted grains of the powder-brazing alloy (Figure 8a). The areas with

tight contact between the surfaces demonstrate a good, porousless joint (Figure 8b).

The joints of (Ni20Cr5,95Al)-Y₂O₃ samples are formed at 1350 °C as a result of sintering of the porous powder brazing alloy due to the processes of diffusion, diffusion creep and crystallization because, as the state diagram of the Ni-B-W powder brazing alloy shows, it is below the solidus when the brazing temperature is 1350 °C. The forces ensuring the flowing of the brazing alloy are the capillary forces which are usually inversely related to the size of pores. When there is no tight contact between the surfaces, the pores are large and the capillary forces are weak. No tungsten in the brazing alloy's composition results in the porous texture and drastic degradation of mechanical properties (Figure 9). During brazing, one should ensure that the area of brazing is isolated properly from carbon which is usually used in vacuum furnaces for heating elements and for the worktable lining.

The analysis of physical and mechanical properties of the material showed that tensile strength of the obtained joint of the (Ni20Cr5.95Al)-Y₂O₃ alloy is 320±10 MPa. The effect of the number of heating

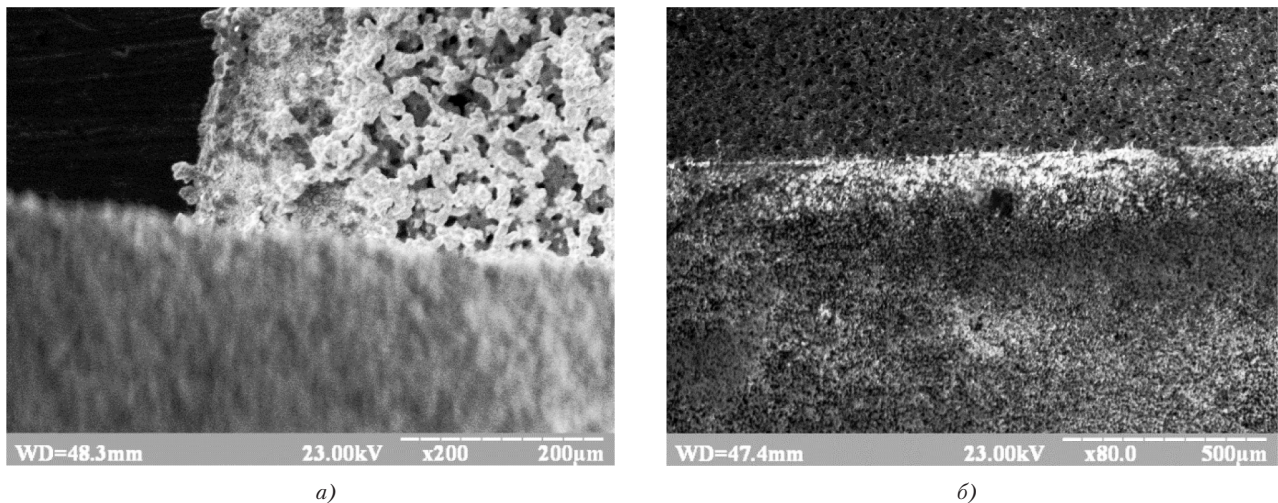

Fig. 8. Microstructure of a joint of two (Ni20Cr5,95Al)-Y₂O₃ plates with different thickness a – with no tight contact between the surfaces; b – with tight contact between the surfaces

The element distribution in a seam section (point by point)

Spectrum	C	O	Al	Si	Ca	Ti	Cr	Fe	Ni	Y	Total
2 Islom	80.17	12.22						7.61			100.00
2 poverxn chva	57.25	34.93		2.52	1.15	0.47	1.15	2.54			100.00
2 pov. chva	52.16	34.96		4.60	2.93	0.47	1.31	3.11	0.45		100.00
1 posle payki	84.52	2.77			0.14	0.18	2.44		9.95		100.00
3 Isxodn	7.75	2.51	6.16				17.55		64.33	1.70	100.00
Max	84.52	34.96	6.16	4.60	2.93	0.47	17.55	7.61	64.33	1.70	
Min	7.75	2.51	6.16	2.52	0.14	0.18	1.15	2.54	0.45	1.70	

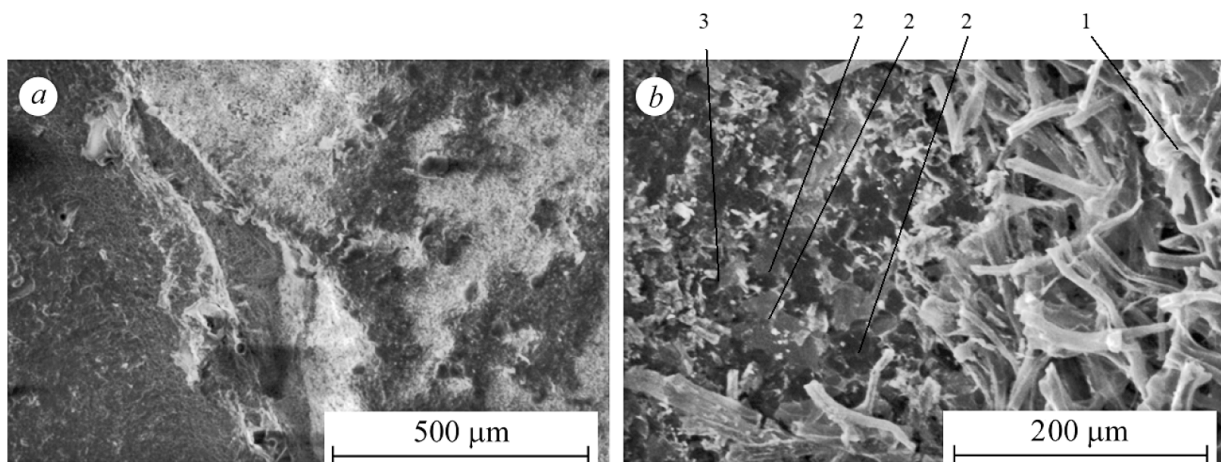

Fig. 9. A porous zone in the area of brazing

cycles on the properties of a brazed joint of the (Ni20Cr5.95Al)-Y₂O₃ alloy was analyzed in order to select a technique of brazing of many joints in one structural element. It was found that 0.15-mm thick plates began to rupture intensely after three heating cycles which imitated the brazing process. So the joining of all the elements of the structure shall be done within one brazing cycle.

The technique of making permanent joints of the components of (Ni20Cr5.95Al)-Y₂O₃ thermal protec-

tion systems by brazing at 1350 °C in vacuum with the use of a Ni-B-W powder-brazing alloy was tried out on a 144 x 144 mm prototype consisting of four samples of three-layer panels attached to each other with U-fasteners (Figure 10a).

Figure 10b shows the prototype of a (Ni20Cr5.95Al)-Y₂O₃ thermal protection system after brazing in a vacuum chamber at 1350 °C for 20 minutes with the use of a Ni-B-W powder-brazing alloy. The all eight joints demonstrate continuous and good seams.

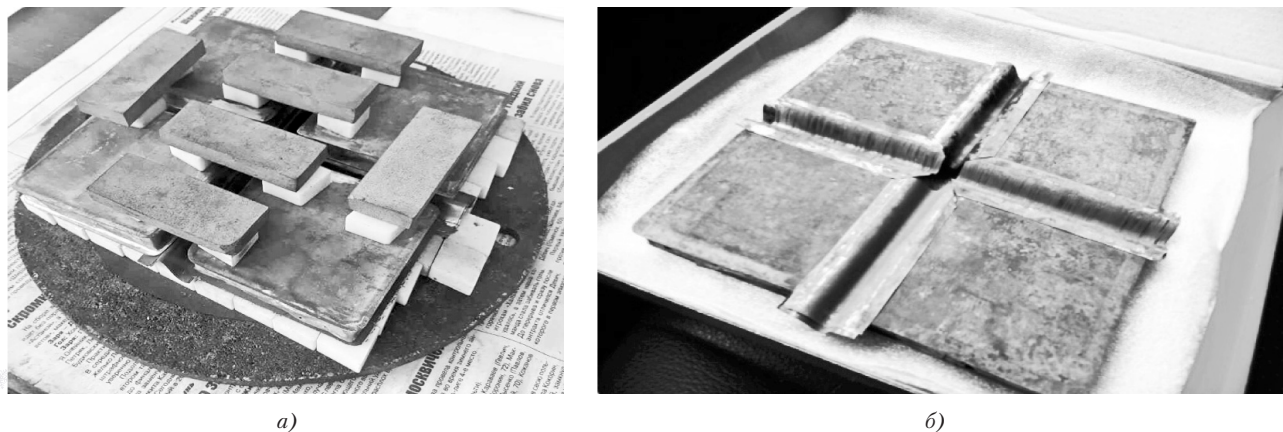

Fig.10. The elements on a vacuum chamber tray (a) and the (Ni20Cr5.95Al)-Y₂O₃ prototype after brazing (b)



Fig. 11. Testing the thermal protection system prototype

No large pores or dry joints are found. The prototype was tested in a high-temperature test chamber by exposure to a gas jet for 30 minutes at up to 1150 °C. The test proved that the U-fasteners ensure the reliable operation of the thermal protection system and prevent its rupture caused by temperature and gas-dynamic deformations (Figure 11).

Hence, a tryout of vacuum brazing proved the technique to be the most appropriate for the assembling of (Ni₂₀Cr_{5.95}Al)-Y₂O₃ outer panels of thermal protection systems for orbital spaceplanes.

Conclusions

The results of the conducted theoretical and experimental studies showed that the following techniques can give permanent joints of the components of (Ni₂₀Cr_{5.95}Al)-Y₂O₃ structures due to diffusion processes running in the contacting materials at temperatures below the melting points of these materials:

Diffusion welding in vacuum through a porous nickel interlayer at a temperature of 900 °C and under specific pressure of 4 MPa for 20 minutes

Vacuum brazing with the use of a Ni-B-W powder-brazing alloy at a temperature of 1350 °C and contact pressure of 0.1 MPa for 20 minutes.

References

- [1] Cook, S.A. "The X-33 Advanced Technology Demonstrator", AIAA Paper 96-1195, April 1996.
- [2] R. J.Hundhausen. "Mechanical Loads Identification and Diagnostics for a Standoff Metallic Thermal Protection System Panel in a Semirealistic Thermo-Acoustic Operating Environment", a thesis submitted

to the Faculty of Purdue University for partial fulfillment of the requirements for a degree of Master of Science in Mechanical Engineering, May 2004.

- [3] Blosser M.L., Martin C.J., Daryabeigi K., Poteet C.C., "Reusable Metallic Thermal Protection Systems Development", Proceedings of the 3rd European Workshop on Thermal Protection Systems, ESTEC, Noordwijk, The Netherlands, 1998, p.165-176.
- [4] Poteet C.C., Blosser M.L., "Improving Metallic Thermal-Protection-System Hypervelocity Impact Resistance Through Numerical Simulation", Journal of Spacecraft and Rockets Vol. 41, No. 2, March-April 2004.
- [5] I. V. Sitnikov, Ye. S. Salomatova, T. V. Olshanskaia, V. Ya. Belenkii. "The analysis of weldability of titanium and high-temperature nickel alloys", Master's Journal №2 (2016), Perm National Research Polytechnic University: 55–59
- [6] R.A. Musin. Diffusion Welding of High-temperature Alloys, edited by R. A. Musin, V. N. Anfitserov, V. F. Kvasnitskii. Moscow: Metallurgiya, 1979
- [7] V. F. Kvasnitskii. "Intensification of diffusion welding of high-temperature alloys", edited by V. F. Krasnitskii and L. I. Markashova. Automatic Welding, 8, 2004: 16–19
- [8] A. I. Ustinov, Yu. V. Falchenko, T. V. Melnichenko, L. V. Petrushinets, K. V. Liapina, A. Ye. Shishkin. "Diffusion Welding of Stainless Steel in Vacuum through Porous Nickel Interlayers", Automatic Welding, 7 (2015): 5–11
- [9] I. A. Husarova, M. Parko, A. M. Potapov, Yu. V. Falchenko, L. V. Petrushinets, T. V. Melnichenko, V. Ye. Fedorchuk. "Analysis of Heat Resistance of a YuIPM-12000 Three-layer Honeycomb Panel Made by Diffusion Welding in Vacuum", Automatic Welding, 12 (2016): 31–35
- [10] B. H. Tsyhan. Carriage Structures, edited by B. H. Tsyhan and A. B. Tsyhan. Kyiv: Kriterii, 2004

Манько Т. А.¹, Гусарова И. А.², Потапов А. М.², Симбиркина А. Н.², Фальченко Ю. В.³,
Саленко А. Ф.⁴, Солнцев В. П.⁵

¹ Днепропетровский национальный университет имени Олеся Гончара. Украина, г. Днепр

² Государственное предприятие «Конструкторское бюро «Южное» им. М. К. Янгеля». Украина, г. Днепр

³ Институт электросварки им. Е. О. Патона НАН Украины. Украина, г. Киев

⁴ Кременчугский национальный университет им. М. Остроградского. Украина, г. Кременчуг

⁵ Институт проблем материаловедения им. И. Н. Францевича НАН Украины. Украина, г. Киев

НАУЧНЫЕ И ТЕХНОЛОГИЧЕСКИЕ АСПЕКТЫ ИЗГОТОВЛЕНИЯ ТЕПЛОЗАЩИТНЫХ КОНСТРУКЦИЙ ОРБИТАЛЬНЫХ САМОЛЕТОВ

Разработана технология получения неразъемных соединений элементов конструкций из сплава (Ni20Cr5,95Al)-Y₂O₃ диффузионной сваркой в вакууме с промежуточной прослойкой и высокотемпературной пайкой в вакууме порошковым припоем Ni-B-W, разработанным авторами. [dx.doi.org/10.29010/085.1]

Ключевые слова: теплозащитная конструкция; жаропрочный сплав; диффузионная сварка; сварные соединения; электронно-лучевое испарение; высокотемпературная пайка.

Литература

- [1] Cook, S.A., "The X-33 Advanced Technology Demonstrator", AIAA Paper 96-1195, April 1996.
- [2] Hundhausen R. J., «Mechanical loads identification and diagnostics for a standoff metallic thermal protection system panel in a semirealistic thermo-acoustic operating environment», A Thesis Submitted to the Faculty of Purdue University In Partial Fulfillment of the Requirements for the Degree of Master of Science in Mechanical Engineering, May 2004.
- [3] Blosser M.L., Martin C.J., Daryabeigi K., Poteet C.C., "Reusable Metallic Thermal Protection Systems Development", Proceeding of the 3rd European Workshop on Thermal Protection Systems, ESTEC, Noordwigk, The Netherlands, 1998, p.165-176.
- [4] Poteet C.C., Blosser M.L., Improving Metallic Thermal-Protection-System Hypervelocity Impact Resistance Through Numerical Simulation, journal of spacecraft and rockets Vol. 41, No. 2, March-April 2004, p.221-231. <http://doi.org/10.2514/1.9193>
- [5] И.В. Ситников, Е.С. Саломатова, Т.В. Олышанская, В.Я. Бельский, Анализ свариваемости жаропрочных никелевых сплавов с титановыми сплавами Master`s journal, 2016, №2, Пермский национальный исследовательский политехнический университет, стр. 55-59.
- [6] Мусин Р.А. Диффузионная сварка жаропрочных сплавов / Р.А. Мусин, В.Н. Анциферов. В.Ф. Квасницкий. – М.: «Металлургия», 1979. – 208 с.
- [7] Квасницкий В.Ф. Интенсификация процесса диффузионной сварки жаропрочных сплавов / В.Ф. Квасницкий, Л.И. Маркашова // Автоматическая сварка. – 2004. – №8. – С. 16 – 19.
- [8] А.И. Устинов, Ю.В. Фальченко, Т.В. Мельниченко, Л.В. Петрушинец, К.В. Ляпина, А.Е. Шишкин Диффузионная сварка в вакууме нержавеющей стали через пористые прослойки никеля / Автоматическая сварка. – 2015. – №7. – С. 5 – 11.
- [9] И. А. Гусарова, М. Парко, А. М. Потапов, Ю. В. Фальченко, Л. В. Петрушинец, Т. В. Мельниченко, В. Е. Федорчук Оценка термостойкости трехслойной сотовой панели, полученной из сплава ЮИПМ-12000 способом диффузионной сварки в вакууме. / Автоматическая сварка, 2016, №12. С.29-33. <http://doi.org/10.15407/tpwj2016.12.05>
- [10] Цыган Б.Г. Вагоностроительные конструкции. Изготовление, модернизация, ремонт/ Б.Г. Цыган, А.Б. Цыган. – К.: Критерий, 2004. – 479 с.